

Air reservoir front, rear part assembly

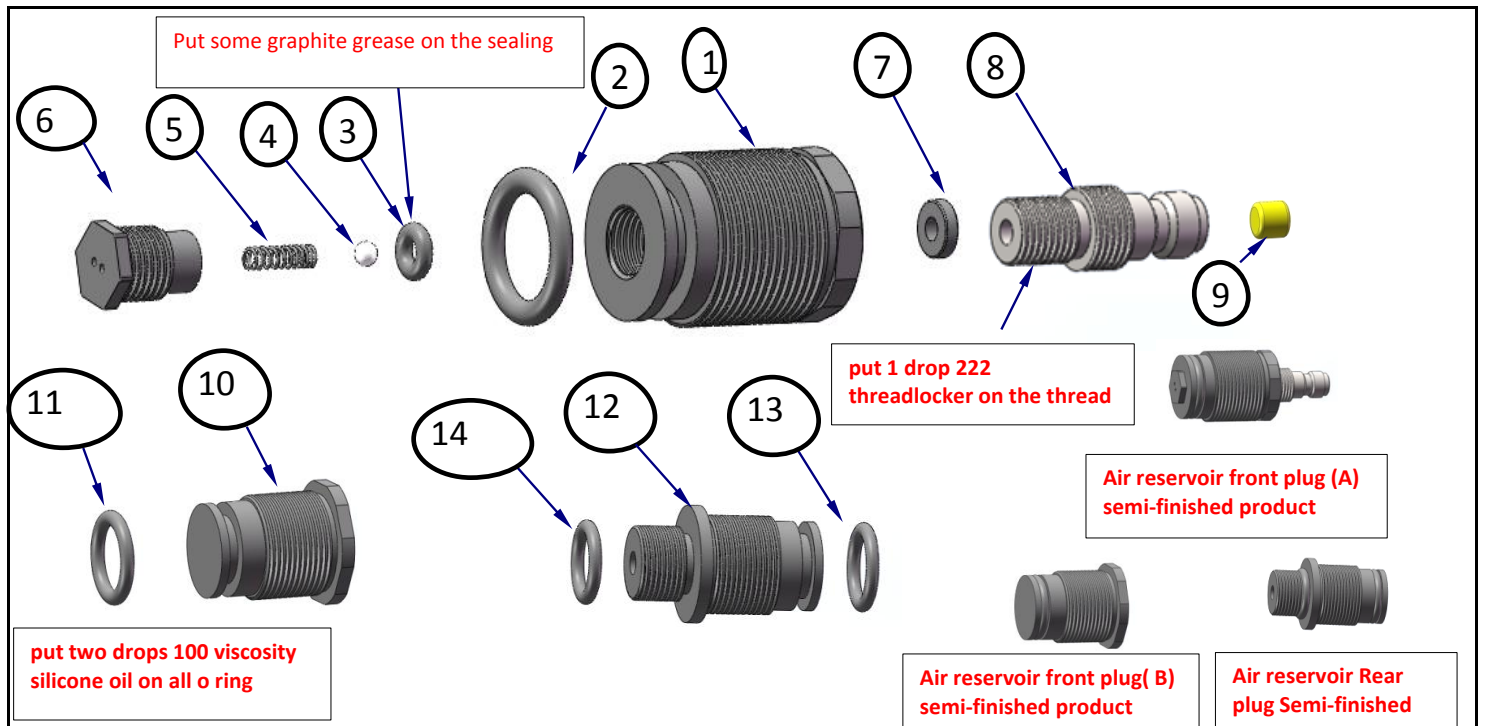

NO	DESCRIPTION	ITEM CODE	USE QTY	REMARKS
1	PS-R Air reservoir front plug (A)	PS-R-025-W-00	1	
2	O ring $\phi 13 * \phi 3$ hardness 90° JSR	PS-007-X-00	1	
3	O ring $\phi 2.5 * \phi 2.5$ hardness 90° JSR	PS-014-X-00	1	
4	Bearing steel ball $\phi 4$ (silver)	000P2-054-W-00	1	
5	Air reservoir front plug check valve spring	000P2-179-W-00	1	
6	PS-R check valve screw	PS-018-W-00	1	
7	3.0 connecting rod washer	000P1-056-S-00	1	
8	Filter element	000P2-175-W-00	1	
9	PS-R fill probe	PS-R-026-W-00	1	
10	PS-R Air reservoir front plug (B)	PS-R-031-W-00	1	
11	O ring $\phi 13 * \phi 3$ hardness 90° JSR	PS-007-X-00	1	
12	PS-R Air reservoir Rear plug	PS-R-028-W-00	2	
13	O ring $\phi 13 * \phi 3$ hardness 90° JSR	PS-007-X-00	2	
14	O ring $\phi 12 * \phi 2.5$ hardness 90° JSR	PS-017-X-00	2	

Air reservoir overall assembly

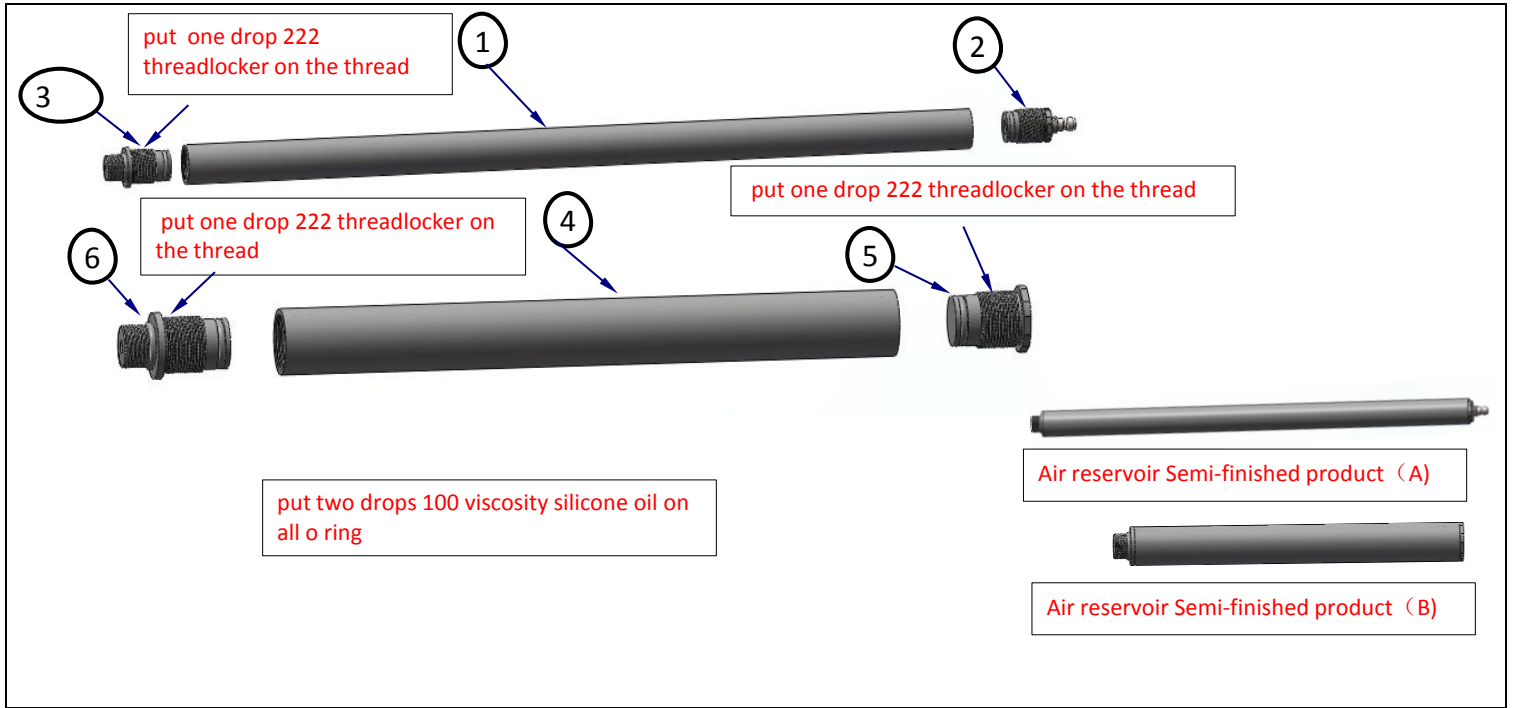

NO	DESCRIPTION	ITEM CODE	USE QTY	REMARKS
1	PS-R Air reservoir tube(A)	PS-R-029-W-00	1	
2	PS-R Air reservoir front plug Semi-finished product (A)	/	1	
3	PS-R Air reservoir Rear plug semi-finished product	/	1	
4	PS-R Air reservoir tube (B)	PS-R-032-W-00	1	
5	PS-R Air reservoir front plug Semi-finished product (B)	/	1	
6	PS-R Air reservoir Rear plug semi-finished product	/	1	

Pellet probe assembly

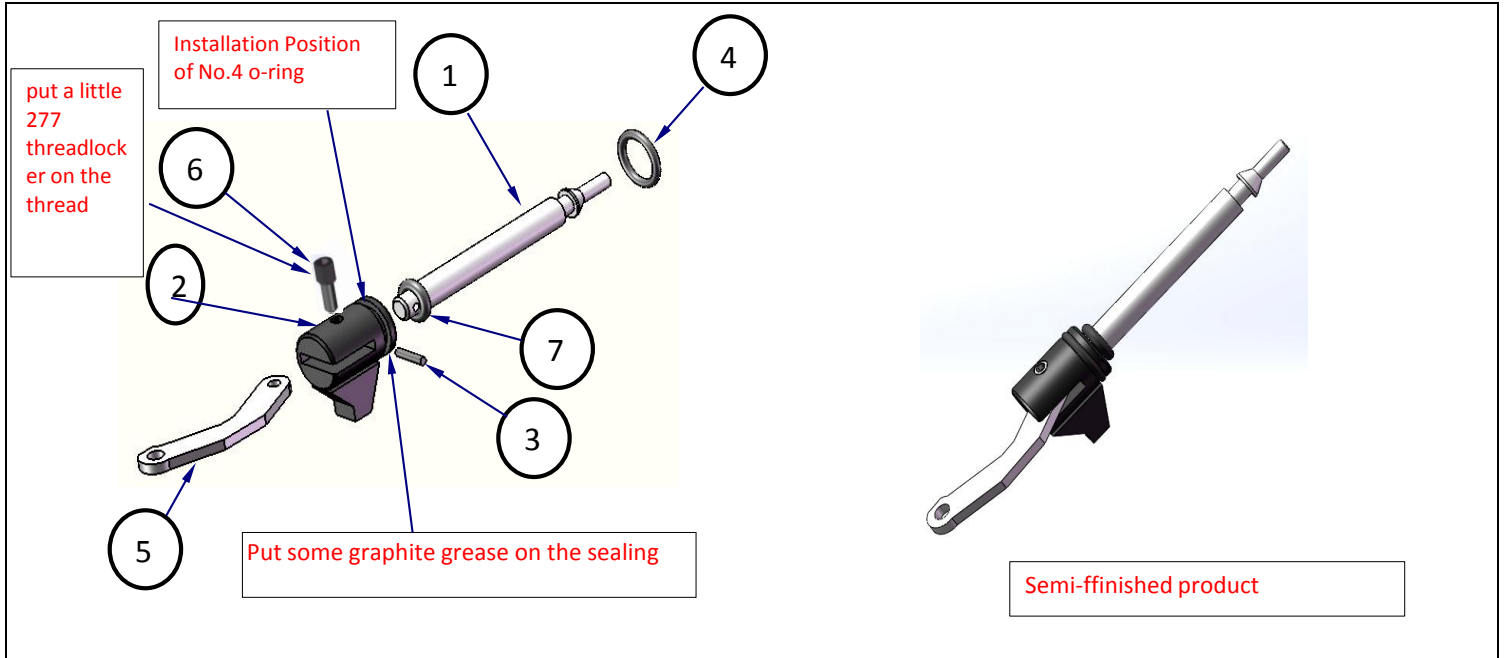

NO	DESCRIPTION	ITEM CODE	USE QTY	REMARKS
1	Cal 4.5mm Pellet probe	000P2-058-W-00	1	
1	Cal 5.5mm Pellet probe	000P1-028-W-00	1	
1	Cal 6.35mm Pellet probe	000P1-084-W-00	1	
2	PS Pellet probe seat	PS-010-W-00	1	
3	Pellet probe pin $\phi 1.5 \times 7$	000P2-064-W-00	1	
4	O ring $\phi 8 \times \phi 1.5$ hardness 90°JSR	PS-011-X-00	1	
5	Side lever action connecting rod	000P2-061-W-01	1	
6	Side lever action connecting rod front pin	000P2-060-W-00	1	
7	O ring $\phi 10 \times \phi 2.5$ hardness 70°	000P1-030-X-00	1	
7	O ring $\phi 9 \times 2.5$ hardness 70°	000P1-029-X-00	1	

Hammer and spring assembly

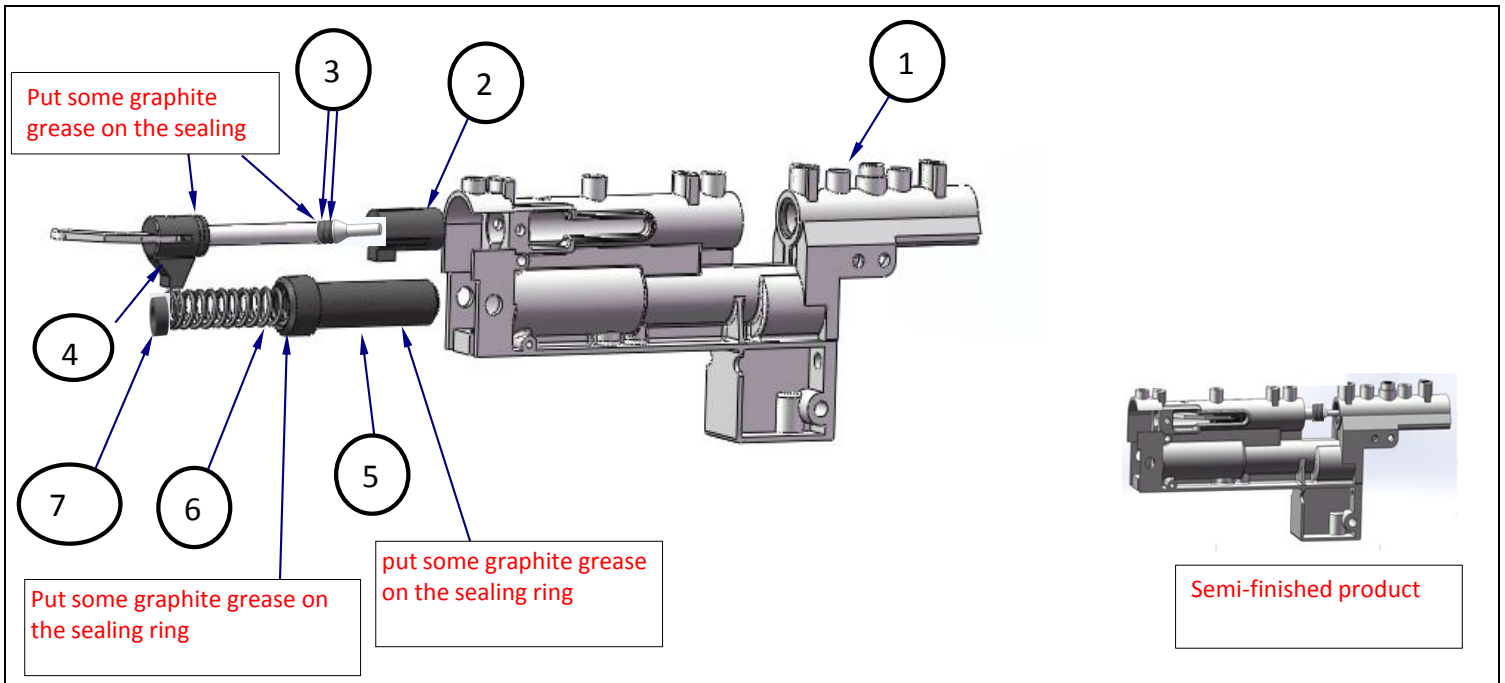

NO	DESCRIPTION	ITEM CODE	USE QTY	REMARKS
1	PS Zinc alloy valve body	PS-R-001-W-00	1	
2	Cal 4.5mm Pellet probe cap	000P2-025-S-00	1	for 4.5mm
2	Cal 5.5mm Pellet probe cap	000P1-008-S-00	1	for 5.5mm
2	Cal 6.35mm Pellet probe cap	000P1-083-S-00	1	for 6.35mm
3	Cal 4.5mm HPA2-4 O ring	OPCP1-001-X-00	2	for 4.5mm
3	Cal 5.5mm O ring $\phi 2.5 * \phi 1.5$ hardness 90° JSR	PS-012-X-00	2	for 5.5mm
3	Cal 6.35mm O ring $\phi 3 * \phi 1.5$ hardness 90° JSR	PS-010-X-00	2	for 6.35mm
4	Pellet probe Semi-finished product	/	1	
5	P1P2 Hammer	000P1-059-W-00	1	
6	Hammer spring(5.5mm/6.35mm)	PS-R-044-W-00	1	for 4.5mm/5.5mm
6	Hammer spring(4.5mm)	PS-R-042-W-00	1	for 4.5mm
7	Hammer spring washer (6.35mm)	PS-R-043-W-00	1	for 6.35mm

Side lever action handle assembly

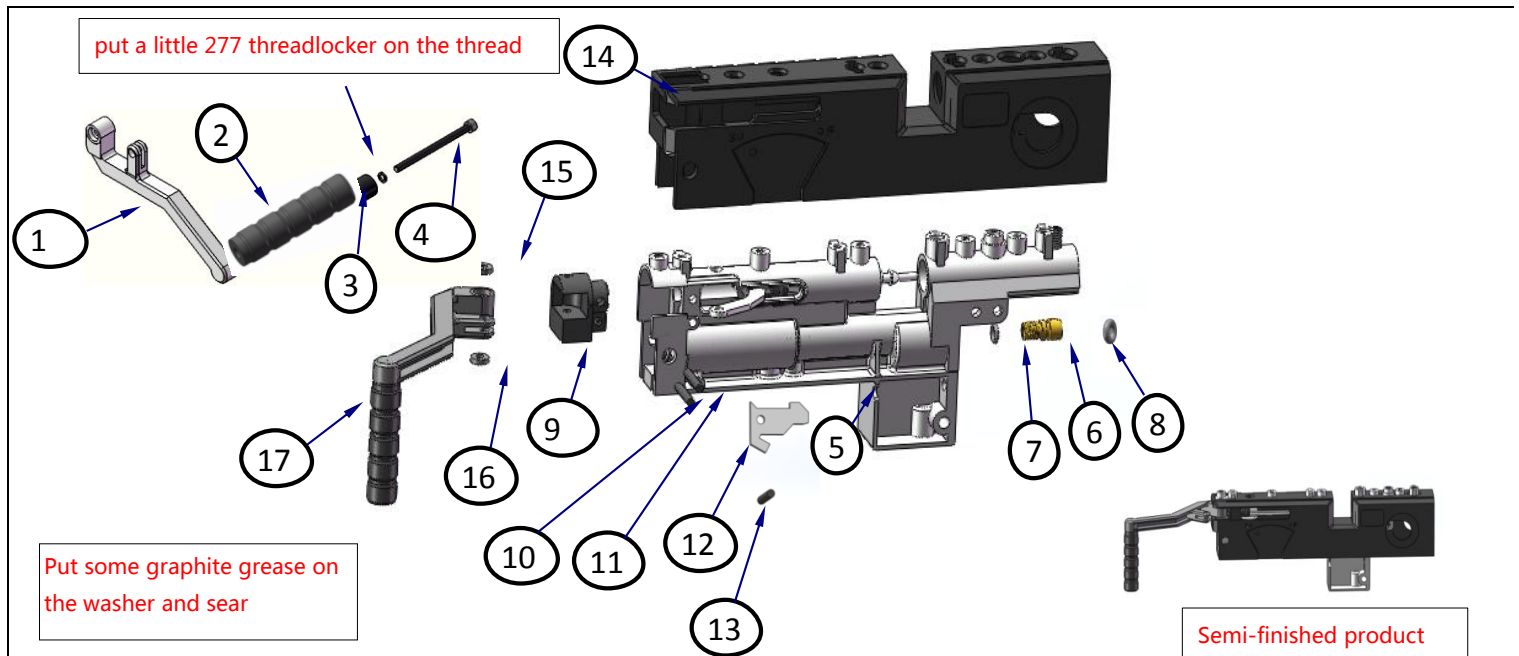

NO	DESCRIPTION	ITEM CODE	USE QTY	REMARKS
1	PS Side lever action pull rod	PS-007-W-00	1	
2	PS Side lever action handle	PS-001-S-00	1	
3	Standard spring washer (M4)	PS-016-W-00	1	
4	Round head allen screw steel M4X45	PS-R-007-W-00	1	
5	valve body semi-finished product	/	1	
6	PS Air release valve screw	PS-015-W-00	1	
7	O ring $\phi 4 * \phi 1.5$ hardness 90° JSR	PS-013-X-00	1	
8	O ring $\phi 3 * \phi 1.5$ hardness 90° JSR	PS-010-X-00	1	
9	PS Side lever action seat	PS-002-S-00	1	
10	PS valve body horizontal pin	PS-008-W-00	1	
11	PS valve body horizontal pin	PS-008-W-00	1	
12	Sear	000P2-081-W-00	1	
13	valve body horizontal pin	PS-R-037-W-00	1	
14	PS shell	/	1	
15	3.0 connecting rod washer	000P1-056-S-00	1	
16	3.0 connecting rod washer	000P1-056-S-00	1	
17	Side lever action pull rod (vertical) semi-finished product	/	1	

Valve body and Cocking bracket assembly

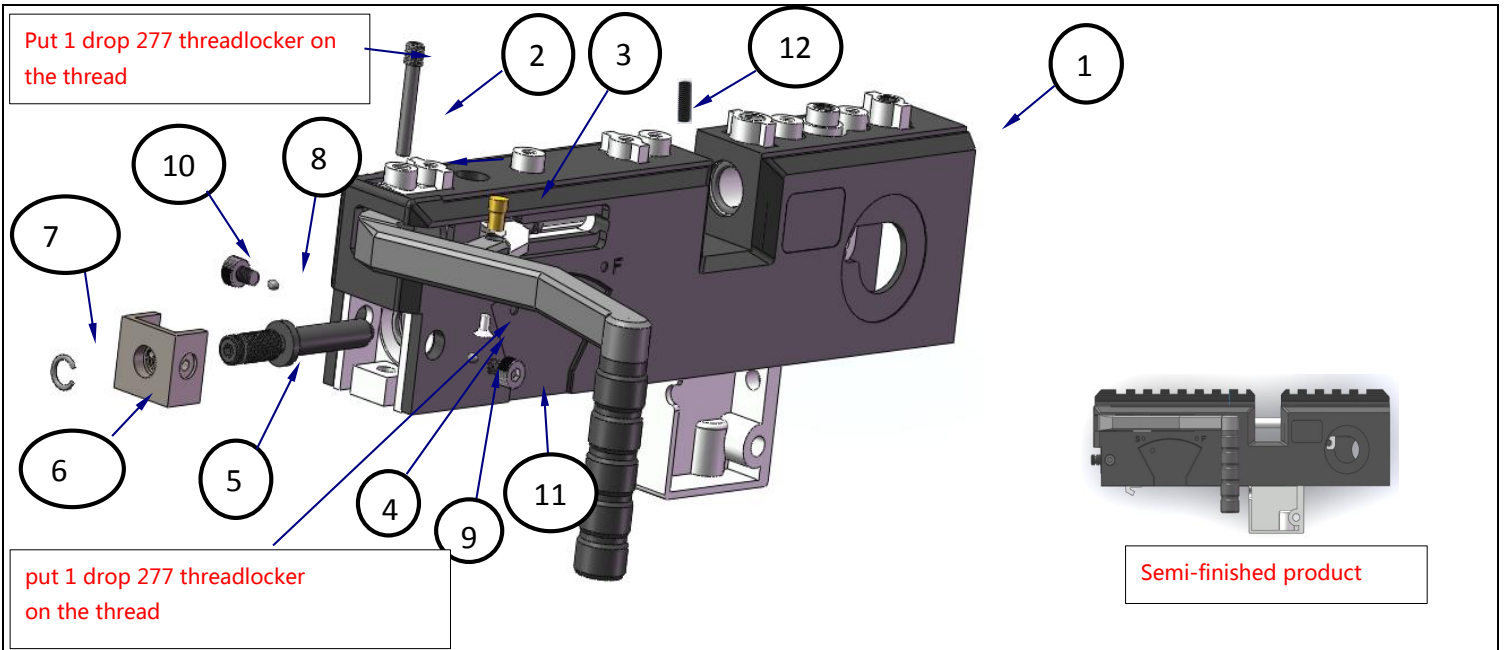

NO	DESCRIPTION	ITEM CODE	USE QTY	REMARKS
1	Valve body	/	1	
2	PS Cocking bracket pin	PS-009-W-00	1	
3	Side lever action pull rod rear screw	000P2-062-W-00	1	
4	Flat head philips screw	000P2-065-W-00	1	
5	Hammer spring adjustment screw	000P2-174-W-00	1	
6	P2 Cocking bracket 2	000P2-007-S-00	1	
7	Hammer spring adjustment clamp spring	000P2-154-W-00	1	
8	POM ball	PS-023-W-00	1	
9	POM ball	PS-023-W-00	1	
10	Round head allen screw M3*4	000P2-052-W-00	1	
11	Round head allen screw M3*4	000P2-052-W-00	1	
12	Flat head allen screw M3*8	000P1-060-W-00	1	

Safety assembly

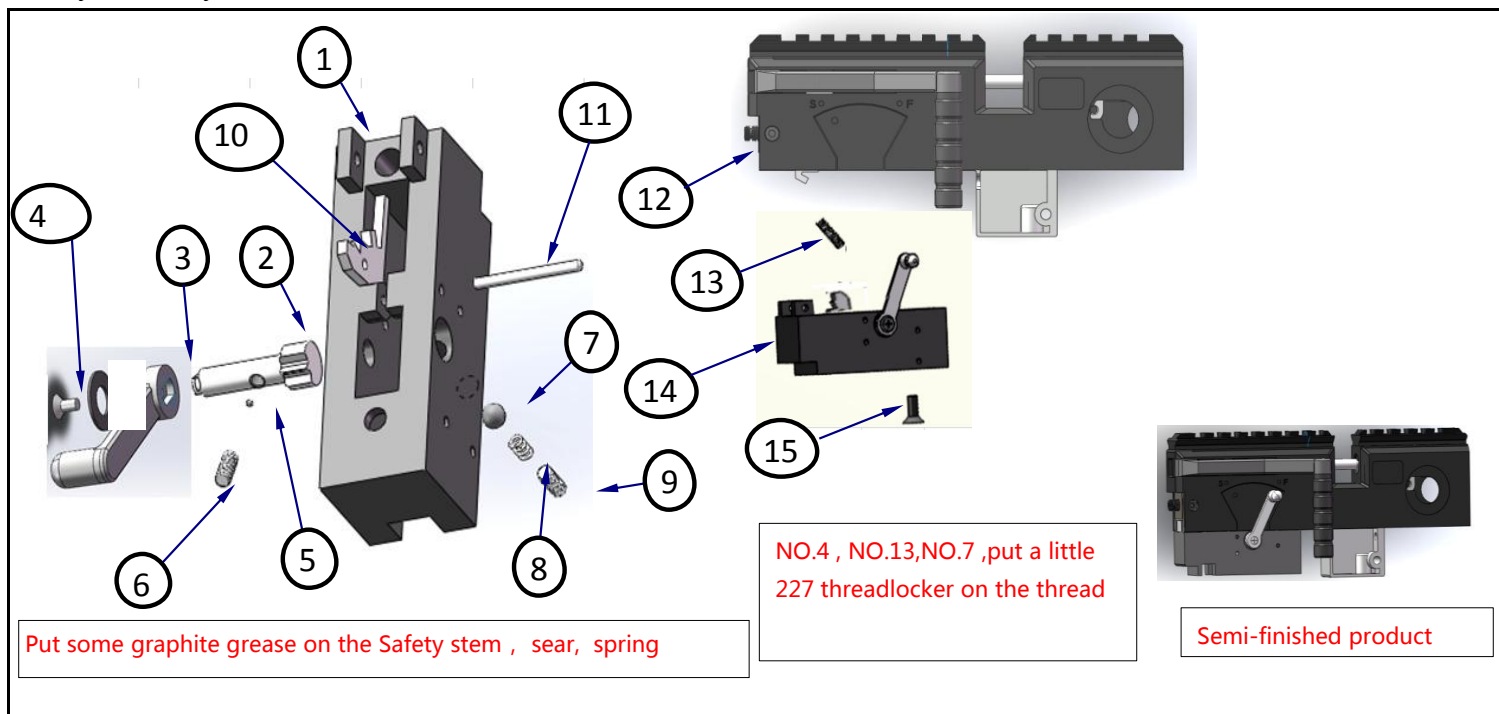

NO	DESCRIPTION	ITEM CODE	USE QTY	REMARKS
1	Cocking bracket 3	000P2-008-S-01	1	
2	Safety stem	000P2-073-W-00	1	
3	Safety rod	000P2-069-W-00	1	
4	Flat head philips screw type-Z M2X5	000P2-070-W-00	1	
5	Steel ball $\phi 1.2$	000P2-162-W-00	1	
6	Flat point allen screw M3X10	000P2-089-W-00	1	
7	Bearing steel ball $\phi 4.4$	000P2-163-W-00	1	
8	Safety spring	000P2-071-W-00	1	
9	Flat point allen screw M5 \times 5	000P2-155-W-00	1	
10	Trigger iron	000P2-080-W-00	1	
11	Aluminum valve body horizontal pin 1	000P2-091-W-00	1	
12	Valve body semi-finished product	/	1	
13	Sear spring	000P2-159-W-00	1	
14	Safety semi-finished product	/	1	
15	Flat head allen screw M4 \times 8	000P2-076-W-00	1	

Trriger semi-finished product

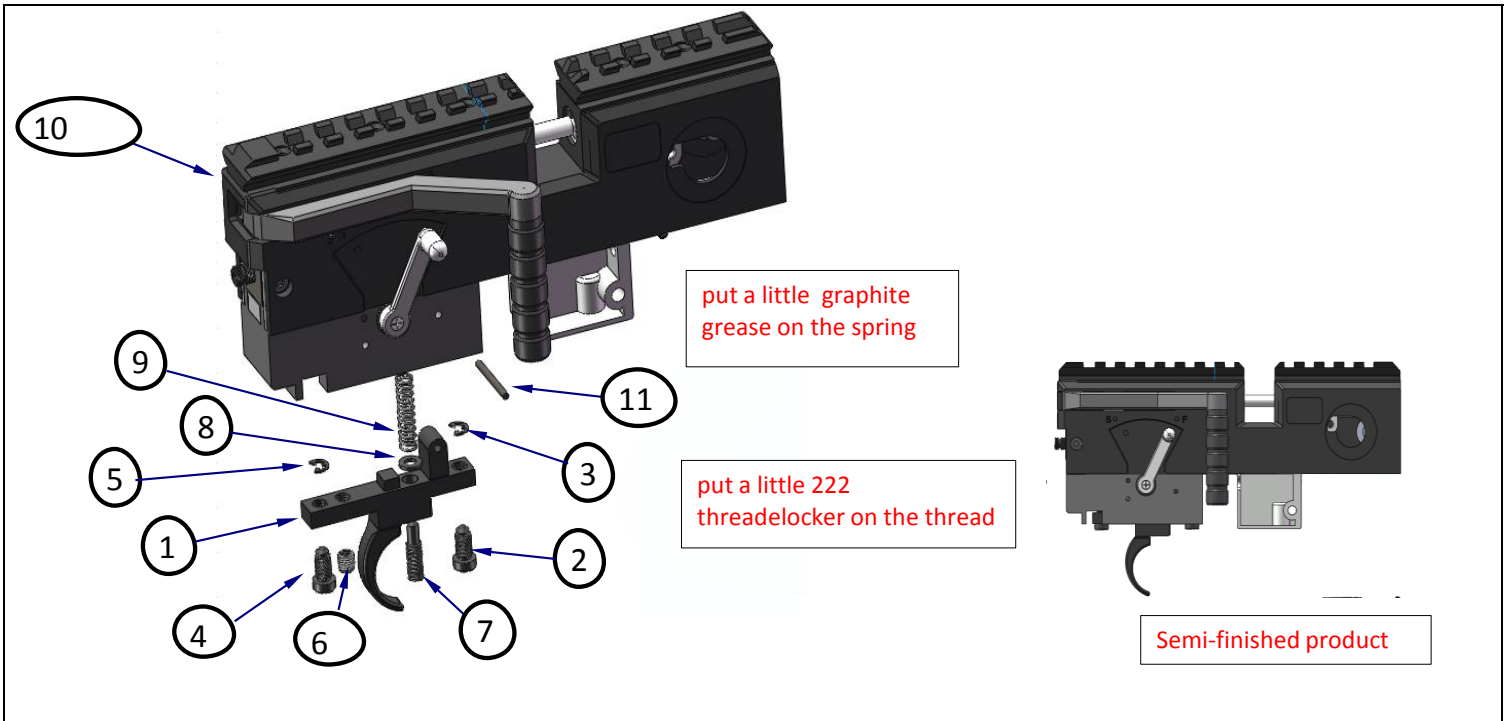

NO	DESCRIPTION	ITEM CODE	USE QTY	REMARKS
1	Trigger	000P2-074-W-00	1	
2	Trigger bracket adjustment screw 2	000P2-088-W-01	1	
3	E clamp spring	000P2-193-W-00	1	
4	Adjustment screw 2	000P2-088-W-01	1	
5	E clamp spring	000P2-193-W-00	1	
6	Flat point allen screw M5X4	000P2-161-W-00	1	
7	Trigger pull adjustment screw	000P2-144-W-00	1	
8	Trigger pull adjustment flat washer	000P2-143-W-00	1	
9	Trigger spring	000P2-158-W-00	1	
10	Valve body semi-finished product	/	1	
11	Aluminum valve body horizontal pin 1	000P2-091-W-00	1	

Pressure relief valve front part assembly

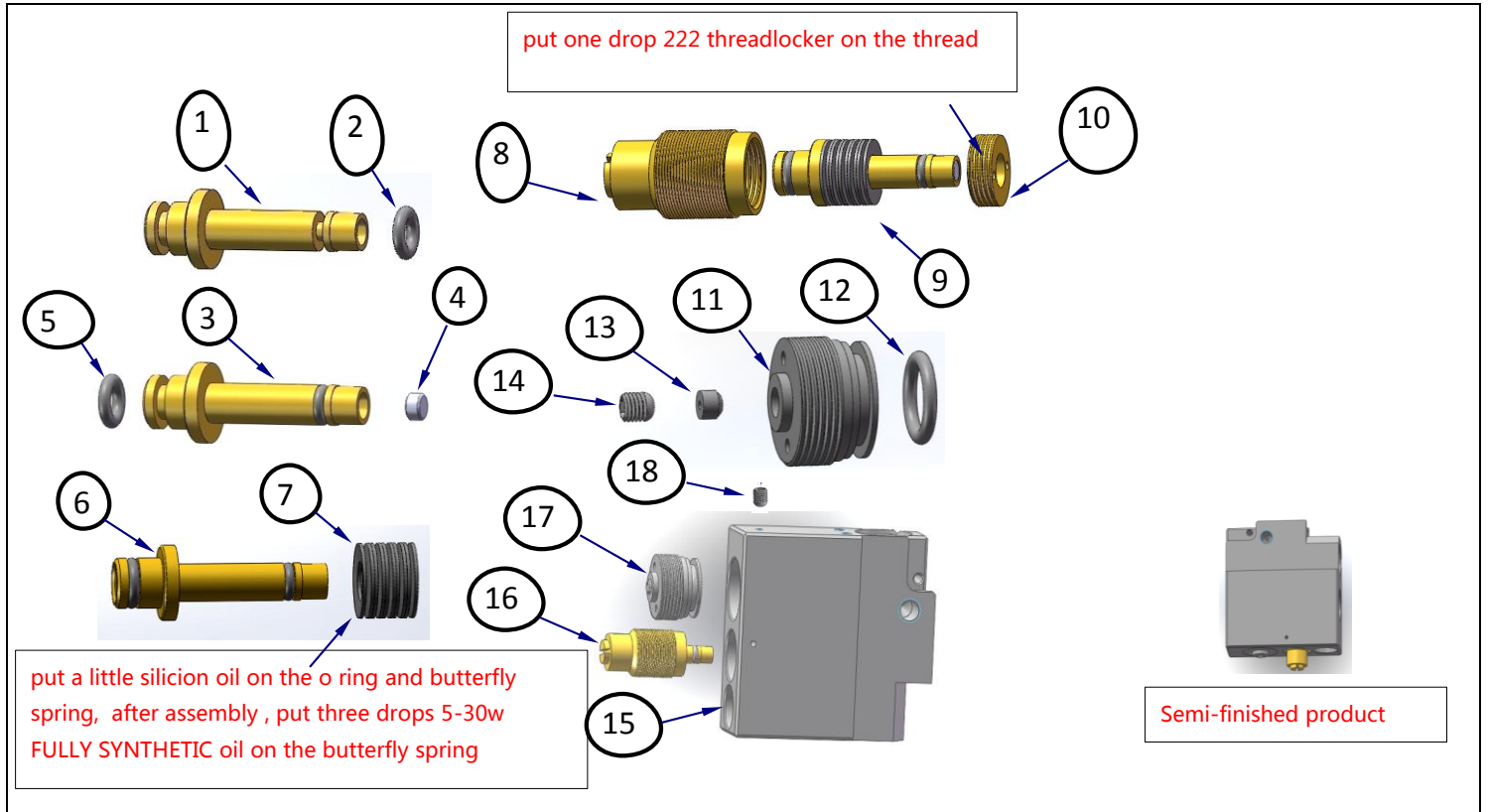

NO	DESCRIPTION	ITEM CODE	USE QTY	REMARKS
1	PS-R Pressure relief valve stem	PS-R-021-W-00	1	
2	O ring $\phi 2.4^* \phi 1.8$ hardness 90° JSR	000P2-072-X-00	1	
3	PS-R Pressure relief valve stem semi-finished product	/	1	
4	PS-R Pressure relief valve washer	PS-R-008-S-00	1	
5	O ring hardness 90° $\phi 4^* \phi 2$ JSR	000P2-073-X-00	1	
6	PS-R Pressure relief valve stem semi-finished product	/	1	
7	3.0 Pressure relief valve butterfly spring	000P2-103-W-01	10	
8	PS-R Pressure relief valve cap	PS-R-020-W-00	1	
9	PS-R Pressure relief valve stem semi-finished product	/	1	
10	PS-R Pressure relief valve screw	PS-R-023-W-00	1	
11	PS-R Pressure relief valve plug	PS-R-017-W-00	1	
12	O ring hardness 90° $\phi 15.08^* \phi 2.62$ Modei616	PS-R-007-X-00	1	
13	Pressure relief valve plug	PS-R-006-S-00	1	
14	Flat point allen screw M6*8	000P2-164-W-00	1	
15	PS-R2 Pressure relief valve body semi-finished product	PS-R2-001-W-00	1	
16	Pressure relief valve semi-finished product	/	1	
17	PS-R Pressure relief valve plug semi-finished product	/	1	

Pressure relief valve rear part assembly

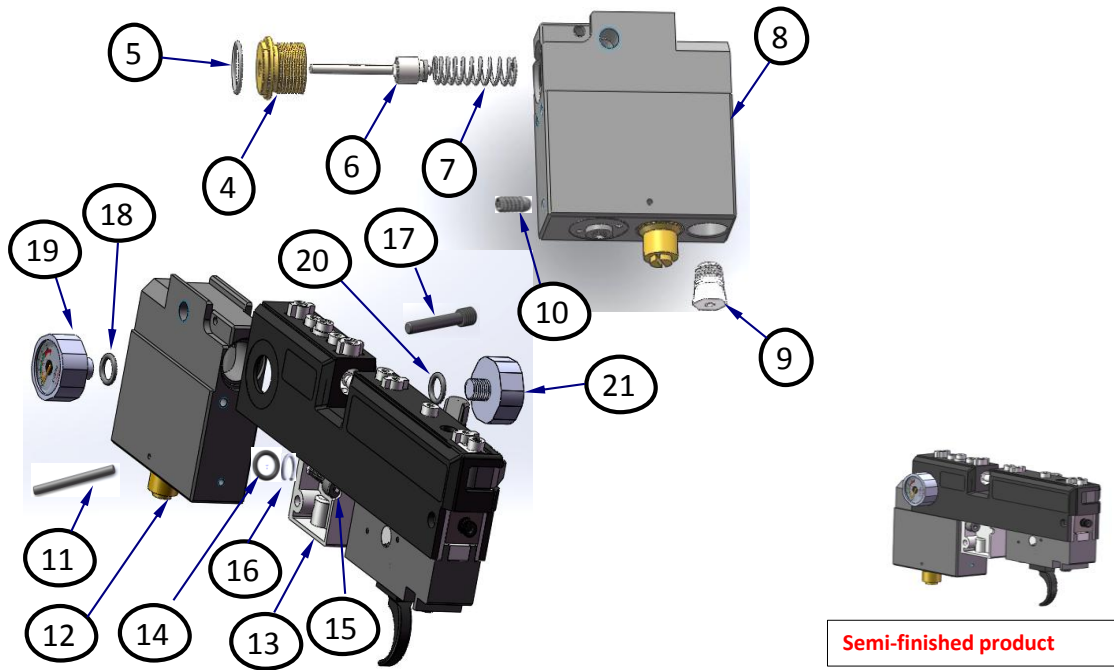

Semi-finished product

NO	DESCRIPTION	ITEM CODE	USE QTY	REMARKS
4	Air release valve sleeve	PS-R-013-W-01	1	
5	O ring $\phi 15^* \phi 1.5$ hardness 90° JSR	PS-006-X-00	1	
6	Air release valve stem		1	
7	PS air release valve spring	PS-014-W-00	1	
8	Pressure relief valve plug semi-finished product	/	1	
9	Safety valve 6K	000P1-022-Z-00	1	
10	Cone point allen screw	PS-R-039-W-00	1	
11	PS-R pin	PS-R-040-W-00	1	
12	Pressure relief valve semi-finished product	/	1	
13	Valve body semi-finished product	/	1	
14	O ring $\phi 9^* \phi 2$ hardness 90°JSR	PS-001-X-00	1	
15	Round head allen screw M4*12	PS-R-038-W-00	2	
16	Standard spring washer	PS-016-W-00	2	
17	PS Cocking bracket pin	PS-009-W-00	1	
18	washer	PS-004-S-00	1	
19	P1 air pressure gauge	000P1-002-W-01	1	
20	washer	PS-004-S-00	1	
21	PS-R Low pressure gauge	PS-R-018-W-00	1	

Valve body and barrel part assembly

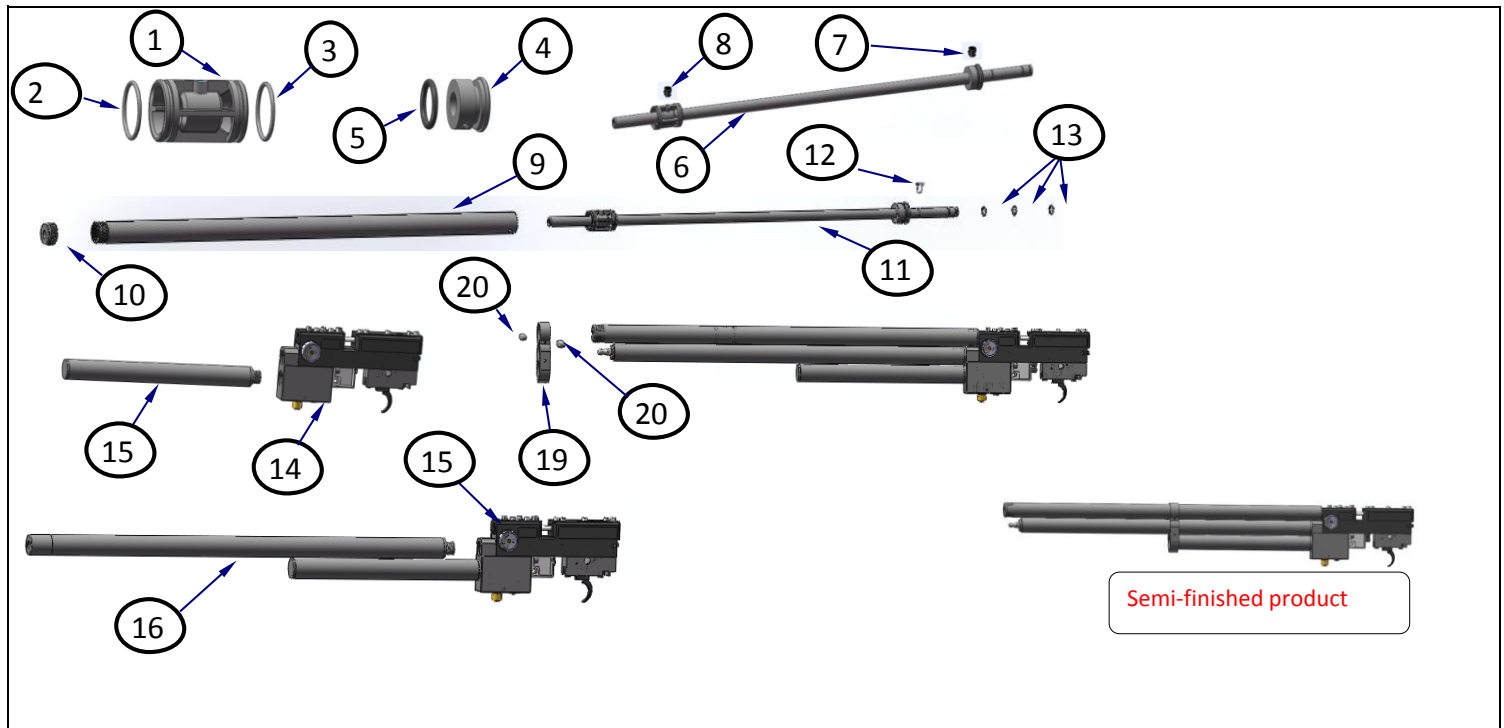

NO	DESCRIPTION	ITEM CODE	USE QTY	REMARKS
1	Front support sleeve	PS-003-S-00	1	
2	NBR o-ring $\phi 19 \times 1.5$ hardness 70°	PS-005-X-00	1	
3	NBR o-ring $\phi 19 \times 1.5$ hardness 70°	PS-005-X-00	1	
4	Shroud barrel rear support sleeve	000P2-004-S-00	1	
5	NBR o-ring OD $\phi 23 \times 3$ hardness 70°	000P2-028-X-00	1	
6	4.5mm barrel	PS-011-W-00	1	for 4.5mm
6	5.5mm barrel	PS-019-W-00	1	for 5.5mm
6	6.35mm barrel	PS-011-W-00	1	for 6.35mm
7	Cone point allen screw M4×6	000P2-036-W-00	1	
8	Cone point allen screw M4×6	000P2-036-W-00	1	
9	Shroud barrel	000P2-035-W-00	1	
10	Shroud barrel front plug	000P2-002-S-00	1	
11	Barrel semi-finished product	/	1	
12	Flat head allen screw M3×5	000P2-032-W-00	1	
13	O-ring $\phi 8 \times 1.5$ hardness 90° JSR	PS-011-X-00	3	
14	Valve body semi-finished product	/	1	
15	Air reservoir (B) Semi-finished product	/	1	
16	Air reservoir (A) Semi-finished product	/	1	
19	PS-R Shroud ring	PS-017-W-00	1	
20	Cone point allen screw M4×8	000P2-059-W-00	2	

Valve body and rail parts assembly

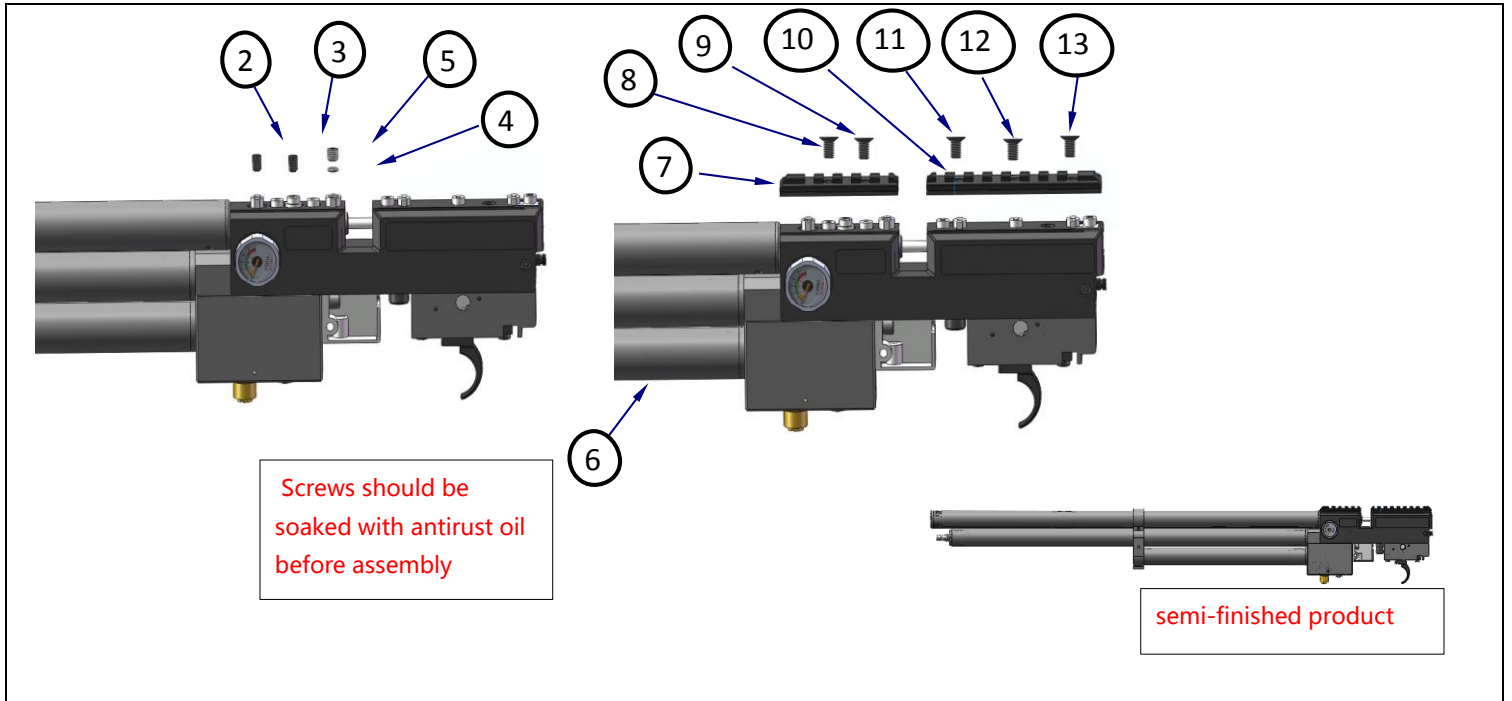

NO	DESCRIPTION	ITEM CODE	USE QTY	REMARKS
2	Cone point allen screw M5×8	000P2-038-W-00	1	
3	Cone point allen screw M5×8	000P2-038-W-00	1	
4	O-ring $\phi 1 \times 2$ hardness 90° JSR	000P2-067-X-00	1	
5	Cone point allen screw M6×6	000P2-039-W-00	1	
6	Gun body semi-finished product	/	1	
7	PS short rail	PS-006-W-00	1	
8	Flat head allen screw M3×6	PS-R-004-W-00	1	
9	Flat head allen screw M3×6	PS-R-004-W-00	1	
10	PS Long rail	PS-005-W-00	1	
11	Flat head allen screw M3×6	PS-R-004-W-00	1	
12	Flat head allen screw M3×6	PS-R-004-W-00	1	
13	Flat head allen screw M3×6	PS-R-004-W-00	1	

Stock assembly

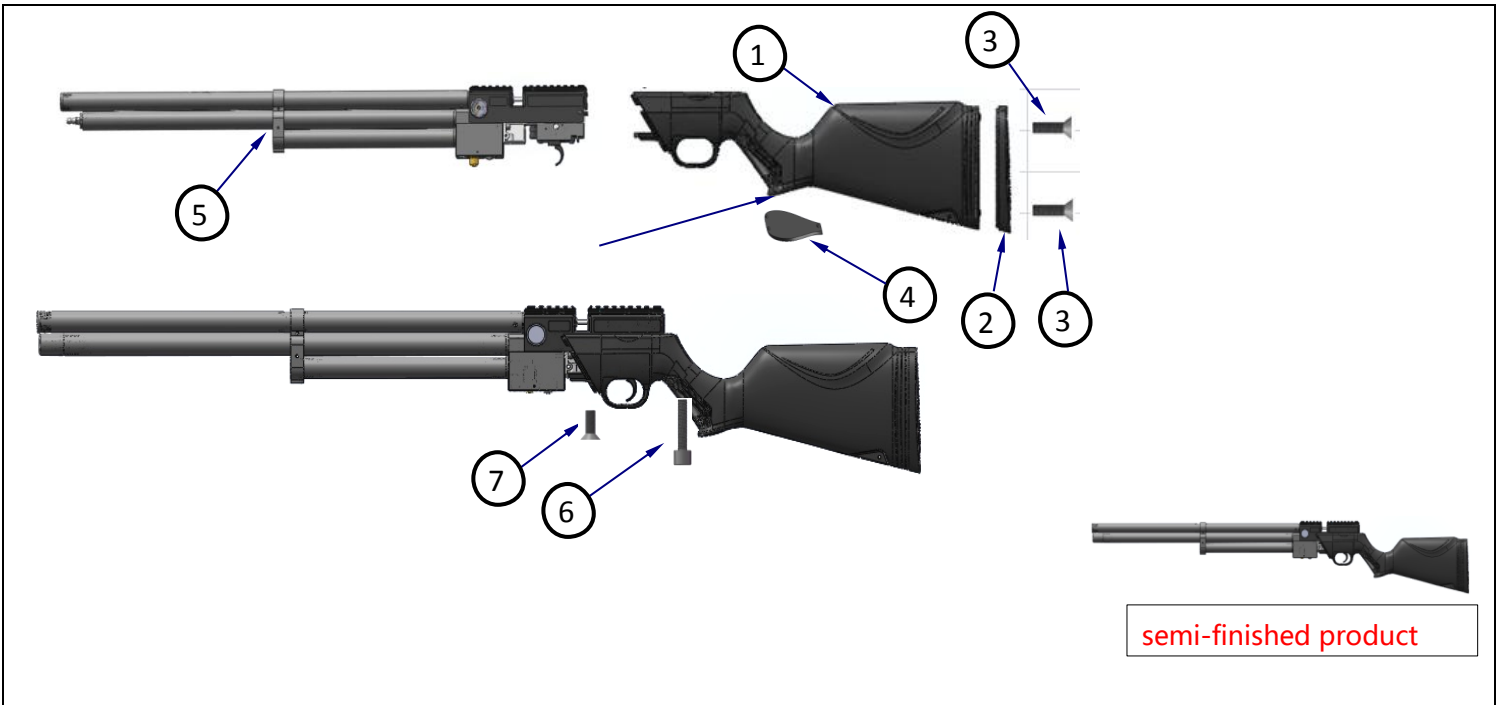

NO	DESCRIPTION	ITEM CODE	USE QTY	REMARKS
1	Rear stock	PS-005-S-00	1	
2	Rubber	PS-011-S-00	1	
3	Flat head allen screw M5*40	000P1-051-W-00	2	
4	Cover	PS-009-S-00	1	
5	Gun semi-finished product	/	1	
6	Round head allen screw steel M5*32	000P2-115-W-00	1	
7	Flat head allen screw M5X14	000P2-109-W-00	1	